

Index du dossier de réception d'une homologation par type en application d'un Règlement
Index to the information package of a type approval with regard to a Regulation

Dernière Série d'amendements applicable <i>Last applicable Series of amendments</i>	N° de la réception de base et mise à jour <i>Base approval and update No</i>	Extension N° <i>Extension No</i>	Révision N° <i>Revision No</i>	Date d'émission <i>Issue date</i>	Fiche de renseignements <i>Information document</i>	
					Référence <i>Reference</i>	Nombre de pages <i>Number of pages</i>
65-00	00	-	-	03.08.2012	AXIXTECH MS26 XA2 /00	4

Vu pour être annexé à la fiche de réception,
Approved and to be attached to the approval certificate,
L'Attaché,
The Attache,



ir. A. DESCAMPS

N° d'homologation mis à jour : <i>Updated Approval No</i>	E6-65R-000028	BEVASYS :	201205267
Mise à jour n° : <i>Update No</i>	00	Date d'émission : <i>Issue date</i>	03.08.2012
		P 1	



COMMUNICATION CONCERNANT L'HOMOLOGATION D'UN TYPE DE FEUX-SPÉCIAL D'AVERTISSEMENT
COMMUNICATION CONCERNING THE APPROVAL GRANTED OF A TYPE OF SPECIAL WARNING LAMP
POUR AUTOMOBILES, EN APPLICATION DU RÈGLEMENT No 65-00
FOR MOTOR VEHICLES, PURSUANT TO REGULATION No. 65-00

N° d'homologation : E6-65R-000028
Approval No.

Marque d'homologation :
Approval mark

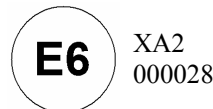

1. Feu spécial d'avertissement / ~~tournant~~ / à ~~éclat stationnaire~~ / a ~~éclat directionnel~~ ~~rampe complète~~ / ~~de couleur bleue~~ / de couleur ~~jauane-auto~~ / ~~rouge~~¹
1. *Special warning lamp / ~~rotating~~ / ~~stationary flashing lamp~~ / ~~directional flashing lamp~~ / ~~complete bar~~ / ~~blue~~ / ~~amber~~ / ~~red~~¹*
2. Le feu spécial d'avertissement a ~~un~~ /deux niveaux d'intensité¹
2. *Special warning lamp has ~~one~~ / two levels of intensity¹*
Le feu spécial d'avertissement est composé de ...unités distinctes...
Special warning lamp consists of separate units.
3. Pour les feux spéciaux d'avertissement ayant deux niveaux d'intensité système employé pour obtenir une intensité renforcée de jour :
3. *For special warning lamps having two levels of intensity, indicate the system used to obtain increased intensity at daytime :
Daytime : Normal system
PWM used to decrease the intensity at night*
4. Source lumineuse utilisée,
4. *Used light source,*
- Catégorie de lampe à incandescence ou ;
category of filament lamp or ;
- Source lumineuse à décharge... ou ;
gas discharge light source or ;
- Source lumineuse à DEL oui / ~~non~~¹ ou ;
LED 12LEDs / 4 light sources yes / ~~no~~¹ or ;
Module d'éclairage : ~~oui~~ / non¹
Light source module: ~~yes~~ / no¹
Code d'identification spécifique du module d'éclairage : -
Light source module specific identification code:
5. Tension nominale de feu spécial d'avertissement : 12V, 18W / 24V, 18W
5. *Rated voltage of special warning lamp :*
6. Marque ou désignation commerciale : AXIXTECH
6. *Trade name or mark :*

¹ Biffer les mentions qui ne conviennent pas - *Strike out what does not apply*

7. Nom et adresse du fabricant:
7. *Manufacturer's name and address :*
- JULUEN ENTERPRISE CO., LTD.
8F-1, No. 502, Da An Rd. Shulin District
Xinbei City, Taiwan
8. Le cas échéant, nom et adresse du représentant du fabricant : -
8. *If applicable, name and address of manufacturer's representative : .*
9. Présenté à l'homologation le: 20.06.2012 ~ 19.07.2012
9. *Submitted for approval on :*
10. Service technique chargé des essais d'homologation:
10. *Technical service responsible for approval tests :*
- AIB VINCOTTE INTERNATIONAL
Jan Olieslagerslaan 35
1800 VILVOORDE
11. Date du procès-verbal délivré par ce service : 03.08.2012
11. *Date of report issued by that service :*
12. Numéro du procès –verbal délivré par ce service : H1260347978/125
12. *Number of report issued by that service :*
13. L'homologation est accordée / étendue¹
13. *Approval granted / ~~extended~~¹*
14. Motif (s) de l'extension (le cas échéant) : -
14. *Reason(s) of extension (if applicable) :*

15. Lieu : Bruxelles
15. *Place*
16. Date : 03.08.2012
16. *Date*
17. Signature :
17. *Signature*

AU NOM DU MINISTRE :
ON BEHALF OF THE MINISTER
Pour le Directeur Général,
For the Director General
L'Attaché,
The Attache,



ir. A. DESCAMPS

18. On trouvera en annexe à la présente communication, la liste des pièces constituant le dossier d'homologation déposé auprès du Service administratif qui a accordé l'homologation; ces pièces peuvent être obtenues sur demande
18. *The list of documents filed with the Administrative Service which has granted approval and available on request is annexed to this communication.*

**AIB-VINÇOTTE International n.v.**

Head office: Diamant Building – A. Reyerslaan 80 – B-1030 Brussels

Company number : BE 0462.513.222 – HRB : 621315 – Internet : www.vincotte.com Safety, quality and environmental services

ISO/IEC 17020 Accredited inspection body - Accreditation certificate BELAC No. 016-INSP

AUTOMOTIVE CERTIFICATION

Business Class Kantorenpark – Jan Olieslagerslaan 35 – B-1800 Vilvoorde

Telephone : +32 (0)2/674.58.85 – Fax : +32 (0)2/674.59.62

E-mail: homologation@vincotte.be**1. SUBJECT : SPECIAL WARNING LAMP**

R65-00

2. **REF. :** Report number : **H1260347978/125** No. of pages : 1 of 12 No. of annexes : -
Bevasys : 201205267 Approval No. : (0028 00) Update : 00

3. GENERALITIES :

Make of Device : AXIXTECH

Commercial Type : -

Manufacturer's Type : MS26 XA2

Name and address of the manufacturer :

JULUEN ENTERPRISE CO., LTD.

8F-1, No. 502, Da An Rd. Shulin District

Xinbei City, Taiwan

4. **TESTS :** Date and place : 2012.06.20 to 2012.07.19
SUN-JET VISIBLE LIGHT LABORATORY

Applied document(s) : AXIXTECH MS26 XA2 / 00

AVI Inspector : LU WAN-CHING

Persons witnessing the tests : LU WAN-CHING

Location of E-mark : On the lamp

5. CONCLUSIONS :

The tests were carried out according to the following specifications :

- UNECE Regulation No. 65 incorporating supplement 7 to the original version.

The models presented comply with the requirements to be applied.

Date : 2012.08.03

Signature :

AIB-Vincotte International n.v.s.a
LU Wan-Ching
Automotive Certification

Handwritten signature of LU Wan-Ching over the Vincotte logo.

DESCRIPTION OF THE TESTED HEADLAMP

Special warning lamp type	:	rotating/stationary flashing lamp /directional flashing lamp/ complete bar
Color	:	blue/amber/red
Nr of separate units	:	-
Light source	:	LED
Number of light source(s)	:	12LEDs / 4 light sources
Voltage and wattage	:	12V 18W / 24V 18W
Light source module	:	Yes / No
Light source module specific identification code	:	-

GENERAL SPECIFICATIONS

Characteristics concerned and prescriptions to apply	References	Conformity	Not applied
The special warning lamps must be so designed and constructed that in normal conditions of use, and notwithstanding the vibrations to which they may be subjected in such use, their satisfactory operation remains assured and they retain the characteristics prescribed by this Regulation.	5.1.	X	
The special warning lamps must be so designed and constructed that the relevant requirements with regard to voltage higher than 50 V are fulfilled.			
The special warning lamp shall be so designed that after it has been mounted correctly on the vehicle, no maladjustment is possible.	5.2.	X	
The special warning lamp shall be powered directly from the voltage supply network of the vehicle by direct connection or usual connectors (e.g. cigarette lighter plug).	5.2.1.	X	
When a non-replaceable light source is used it shall be permanently fixed to the special warning lamp.	5.3.	X	
Light source module	5.4.		X
The design of the light source module(s) shall be such that even in darkness the light source module(s) can be fitted in no other position, but the correct one.	5.4.1.		
The light source module(s) shall be tamperproof.	5.4.2.		
In the case of a system that uses a special power supply, or a dedicated power supply, or light source control gear shall be part of special warning lamp.	5.5.		X
The frequency f , the "on" time t_H and the "off" time t_D shall correspond to the values indicated in the table in Annex 5 to this Regulation. They shall be measured at an ambient temperature of $+23^\circ\text{C} \pm 5^\circ\text{C}$ and with voltages at the terminals of the device which are between 90 per cent and 115 per cent of the rated voltage. Moreover, starting and correct functioning of the special warning lamp shall remain assured at temperatures between -20°C and $+50^\circ\text{C}$ or if the special warning lamp is exposed to heavy rain, in accordance with the procedure described in Annex 4 to this Regulation. Under those conditions, one minute after a voltage equal to 90 per cent of the rated voltage has been applied, the frequency shall remain between 2 and 4 Hz.	5.6.	X	

Characteristics concerned and prescriptions to apply	References	Conformity	Not applicated
A rotating or flashing special warning lamp device of Category T may consist of more than one optical system. In this case the requirements of Annex 5 § 8 must be met. The lamp manufacturer must supply mounting information to ensure that the various units are correctly mounted on a vehicle.	5.7.		X

PHOTOMETRIC SPECIFICATIONS

Characteristics concerned and prescriptions to apply	References	Conformity	Not applicated
The special warning lamps shall comply with the conditions prescribed in Annex 5 to this Regulation.	6.	X	

CHECKING THE COLOUR OF THE SPECIAL WARNING LAMP

Characteristics concerned and prescriptions to apply	References	Conformity	Not applicated
<p>The colour shall comply with the colorimetric boundaries prescribed in Annex 3 to this Regulation.</p> <p>The colorimetric characteristics of the light emitted, expressed in CIE chromaticity co-ordinates, shall be evaluated using the light source as designed, working at the voltage as specified in § 4.2. in Annex 5 of this Regulation.</p> <p>In case of a special warning lamp employing a Xenon flash tube, as an alternative the chromaticity co-ordinates may be deduced from the spectral distribution of the transmission of the cover and the transmission or reflection of any other optical effective elements which could impair the colour of the special warning lamp. The calculation then shall be based on a luminous source with a relative spectral distribution as listed in Annex 6.</p>		X	

TRICHROMATIC CO-ORDINATES FOR THE LIGHT EMITTED THROUGH THE AMBER OR BLUE FILTERS CONSTITUTING THE COVERS OF SPECIAL WARNING LAMPS (ANNEX 3)

Characteristics concerned and prescriptions to apply	References	Conformity	Not applied
<p>Under the conditions of § 7 of this Regulation, the trichromatic co-ordinates of light emitted through the filters used for special warning lamps shall lie within the following boundaries:</p> <p>1. Amber ¹</p> <p>limit towards green : $y \leq x - 0.120$</p> <p>limit towards red : $y \geq 0.390$</p> <p>limit towards white : $y \geq 0.790 - 0.670 x$</p> <p>2. Blue</p> <p>limit towards green : $y = 0.065 + 0.805 x$</p> <p>limit towards white : $y = 0.400 - x$</p> <p>limit towards purple : $y = 1.67x - 0.222$</p> <p>3. Red</p> <p>limit towards purple : $y \geq 0.980 - x$</p> <p>limit towards yellow : $y \leq 0.335$</p>		<p style="text-align: center;">X</p>	<p style="text-align: center;">X</p> <p style="text-align: center;">X</p>

¹ Corresponds to a specific part of the "yellow" zone of the triangle of CIE colours.

PROCEDURE FOR THE RAIN TEST (ANNEX 4)

Characteristics concerned and prescriptions to apply	References	Conformity	Not applied
<p>A sample of the special warning lamp, fitted in its normal operating position, with all the drainage apertures open if they exist, shall be subjected to a precipitation of 2.5 mm of water per minute, the water being directed at an angle of 45° and from a nozzle producing a full conical jet.</p> <p>During the test, the device shall turn on its vertical axis at a rate of 4 turns per minute.</p> <p>The test shall last for 12 hours continuously after which the water jet shall be stopped.</p> <p>One hour later, the sample shall be examined and shall be regarded as having passed the test if the accumulated volume of water does not exceed 2 cm³.</p>		X	

PHOTOMETRIC SPECIFICATIONS (ANNEX 5)

Characteristics concerned and prescriptions to apply	References	Conformity	Not applied
<p>Measurements of the photometric characteristics shall be taken at a distance of at least 25 m.</p> <p>The angular diameter of the photoelectric receiver as seen from the special warning lamp shall be 10 minutes or arc maximum.</p> <p>The response time of the photometric system shall be adequate to the rising time of the signal to be measured.</p>	1.	X	
<p>For special warning lamps having one level of intensity (class1), the "by night" level shall apply.</p> <p>For special warning lamps having two levels of intensity (class 2), measurements shall be carried out for each of the two levels.</p> <p>The effective luminous intensities in various directions shall be as specified in the table below.</p>	2.	X	

Characteristics concerned and prescriptions to apply	References	Conformity	Not applied
<p>If a filament lamp is used that shall be a standard filament lamp as provided for in Regulation No. 37 corresponding to a lamp of the category specified for the special warning lamp.</p>	3.		X
<p>Light source conditions for test:</p>	4.		
<p>In the case of replaceable light sources a standard lamp shall be used.</p>	4.1.		X
<p>All measurements on lamps equipped with replaceable or non-replaceable light sources (filament lamps, gas discharge light sources and other) shall be made at 6.75 V, 13.5 V or 28.0 V, respectively.</p>	4.2.	X	
<p>In the case of a system that uses a special power supply, or a dedicated power supply, or light source control gear, the voltage declared by the manufacturer shall be applied to the input terminals of that power supply. Unless otherwise specified 6.75 V, 13.5 V or 28 V, as applicable shall be used.</p>			
<p>In the case of filament lamps it is allowed to make the measurements with a standard filament lamp at reference flux conditions nearly at 12 V and recalculate the measured values by a factor, which is determined with this standard filament lamp at 13.5 Volt, if applicable.</p>	4.3.		X
<p>For any lamp equipped with non-filament light source(s), the luminous intensities measured after one minute and after 30 minutes of operation shall comply with the minimum and maximum requirements. The luminous intensity distribution after one minute of operation can be calculated by applying the ratio achieved at HV between one minute and 30 minutes of operation.</p>	5.	X	
<p>If the emitted light of a special warning lamp consists of groups of several flashes, the time distance Δt between the immediately following flashes must be very short.</p>	6.	X	
<p>If the peak to peak distance Δt is less or equal to 0.04 s, then the pulses in between are evaluated as one flash. If this distance Δt is longer only the flash with the highest effective intensity is valid. Moreover, the period is limited depending on the ratio between the effective intensities of the flashes within a group (IH= max. effective intensity of the highest peak, IL = max. effective intensity of the lowest peak) as follows:</p>			
<p>in case</p> $\frac{I_H}{I_L} > 10 \text{ then } \Delta_t (s) < \frac{1}{3f}$			
<p>in case</p> $1 < \frac{I_H}{I_L} < 10 \text{ then } \Delta_t (s) < \frac{1}{f(5.50 - 0.25 \frac{I_H}{I_L})}$			

Characteristics concerned and prescriptions to apply	References	Conformity	Not applied
<p>Frequency, time, and intensity of the emitted light</p> <p>The frequency, the "ON" time and the "OFF" time shall be as specified in the table shown in §7.1</p> <p>The effective luminous intensities (J_e) within the relevant vertical angles for a special warning lamp (Category T) shall be as specified in the table shown in §7.2.</p> <p>In the case of a special warning lamp device which is comprised of more than one separate unit, the geometrical arrangement(s) as installed at the vehicle seems to be acceptable, if the partial light distribution of each single separate unit is overlapping with each adjacent partial light distribution inside a horizontal angular range of 360° and in a vertical angular range as specified for the relevant category in a geometrical position corresponding to a distance of 20 m, from the vehicle on a vertical plane that is perpendicular to the longitudinal axis of the vehicle and located midway between the lamp units on a side of the vehicle.</p> <p>The effective luminous intensities in the reference axis for a directional flashing lamp (Category X) shall be as specified in the table shown in §7.3.</p> <p>Table of standard light distribution for special warning flash lamp (Category X)</p> <p>Minimum horizontal angular range of category "narrow angle effect" is 30° left to 30° right and for category "wide angle effect" 90° directed outwards the vehicle and 30° to the inside.</p> <p>The direction $H = 0^\circ$ and $V = 0^\circ$ corresponds to the reference axis. (On the vehicle it is horizontal, parallel to the median longitudinal plane of the vehicle and oriented in the required direction of visibility). It passes through the centre of reference. The values shown in the table give, for the various directions of measurements, the minimum intensities as a percentage of the minimum required in the axis for each lamp (in the direction $H = 0^\circ$ and $V = 0^\circ$).</p> <p>Within the field of light distribution of § 7.3.1. schematically shown as a grid, the light pattern should be substantially uniform, i.e. the light intensity in each direction of lowest minimum value being shown on the grid lines surrounding the questioned direction as a percentage.</p> <p>In the case of a special warning lamp device of Category X which comprises of more than one separate unit, the geometrical arrangement(s) as installed on the vehicle, is(are) acceptable when the partial light distribution of each single separate unit is overlapping with each adjacent partial light distribution inside the horizontal and vertical angular range specified for the Category X.</p>	<p>7.</p> <p>7.1</p> <p>7.2.</p> <p>7.2.1.</p> <p>7.3.</p> <p>7.3.1.</p> <p>7.3.1.1.</p> <p>7.3.1.2.</p> <p>7.3.2.</p>	<p>X</p> <p>X</p> <p>X</p> <p>X</p> <p>X</p> <p>X</p> <p>X</p>	<p>X</p> <p>X</p> <p>X</p>

Characteristics concerned and prescriptions to apply	References	Conformity	Not applied
<p>If two or more optical systems are integrated in one special warning lamp, this unit has to comply with the following requirements:</p> <p>Each optical system shall be in accordance with the requirements of this Annex within the horizontal angle which is not covered by one of the other optical systems. Furthermore, in each required direction at least one optical system shall be effective corresponding to the requirements of this Annex.</p> <p>If a special warning lamp contains two or more optical systems, all the optical systems shall work in phase. This applies only to each half of a complete "bar" which is designed to extend on the width of the vehicle.</p> <p>As long as the efficiency of the special warning lamp is to be secured all around the car a detection of the failure of a part of a special warning system shall exist on the car. If it is designed by the special warning lamp manufacturer this detection shall be checked during the approval procedure.</p>	<p>8.</p> <p>8.1.</p> <p>8.2.</p> <p>8.3.</p>		X

FACILITIES AND EQUIPMENT

The facilities and equipment used to carry out the inspections are in compliance with the requirements of the applied Regulatory Act(s).

Equipment Description

Model Number

SJTC-O-001 Goniophotometer	OPTRONIK SMS 10c
SJTC-O-016 Flash meter	Czibula & Grundmann GmbH Ph-St-B8-Th-Fast
SJTC-O-017 High-Speed Multi Channel Spectrophoto Meter	OTSUKA MCPD-9800(2480)
SJTC-O-011 Power Supply	OPTRONIK SNT10
SJTC-O-021 Oscilloscope	TEKTRONIX DPO3012
SJTC-M-005 Aging Oven Tester	GOLDEN TOP
SJTC-M-015 Temperature & Humidity Tester	GIANT FORCE
Rain Test	TESTING BY JULUEN ENTERPRISE CO., LTD.

TEST RESULTS: For Special Warning Lamp on By Day Level

Light sources : 12LEDs / 4 light sources ; Rated voltage and wattage : 12V 18W / 24V 18W

Specification : Measure the effective luminous intensity J_e .

Test Results of Photometric Measurement and Flash Characteristics Measurement

Lamp Function	: Amber Special Warning Lamp	Test Voltage	: 13.5 V / 28 V
Category&Class	: XA2	Test Distance	: 25 m
Requirement	: ECE Reg. 65 Annex 5		
Effect	: Narrow Effect	Flash Mode	: Double Flash
By Day / By Night	: By Day	“ON” time t_H	: 0.1931 s / 0.1939 s
Frequency (f)	: 2.05 Hz / 2.04 Hz	“OFF” time t_D	: 0.2940 s / 0.2950 s

Point on Measuring Screen	Requirement (cd)		Sample 1 (12V) Measurement (cd)		Sample 2 (24V) Measurement (cd)	
	Min	Max	1 Minute	30 Minutes	1 Minute	30 Minutes
8U - 10L	200	1500	332.8	293.0	374.3	300.9
8U - 10R	200	1500	345.3	304.0	390.1	313.6
6U - 20L	200	1500	383.7	337.7	396.2	318.5
6U - V	300	1500	415.3	365.5	471.0	378.6
6U - 20R	200	1500	391.3	344.5	410.0	329.6
4U - 30L	80	1000	251.9	221.7	254.1	204.3
4U - 10L	400	1500	525.9	462.9	574.6	461.9
4U - 10R	400	1500	545.8	480.5	615.0	494.4
4U - 30R	80	1000	266.0	234.2	257.0	206.6
H - 30L	200	1000	322.0	283.5	317.5	255.2
H - 20L	300	1500	581.2	511.6	606.0	487.1
H - V	400	1500	656.5	578.0	741.1	595.8
H - 20R	300	1500	585.6	515.5	610.2	490.5
H - 30R	200	1000	324.9	286.0	319.8	257.1
4D - 30L	80	1000	272.5	239.9	265.8	213.7
4D - 10L	400	1500	566.1	498.4	603.6	485.2
4D - 10R	400	1500	546.0	480.6	614.2	493.7
4D - 30R	80	1000	260.5	229.3	255.9	205.7
6D - 20L	200	1500	417.8	367.8	406.4	326.7
6D - V	300	1500	436.8	384.5	473.2	380.4
6D - 20R	200	1500	405.9	357.3	401.2	322.5
8D - 10L	200	1500	380.6	335.1	378.1	303.9
8D - 10R	200	1500	367.6	323.6	369.6	297.1

Test Results	<input checked="" type="checkbox"/> Passed	<input type="checkbox"/> Failed
--------------	--	---------------------------------

TEST RESULTS: For Special Warning Lamp on By Night Level

Light sources : 12LEDs / 4 light sources ; Rated voltage and wattage : 12V 18W / 24V 18W

Specification : Measure the effective luminous intensity J_e .

Test Results of Photometric Measurement and Flash Characteristics Measurement

Lamp Function	: Amber Special Warning Lamp	Test Voltage	: 13.5 V / 28 V
Category&Class	: XA2	Test Distance	: 25 m
Requirement	: ECE Reg. 65 Annex 5		
Effect	: Narrow Effect	Flash Mode	: Double Flash
By Day / By Night	: By Night	“ON” time t_H	: 0.1935 s / 0.1941 s
Frequency (f)	: 2.05 Hz / 2.04 Hz	“OFF” time t_D	: 0.2946 s / 0.2955 s

Point on Measuring Screen	Requirement (cd)		Sample 1 (12V) Measurement (cd)		Sample 2 (24V) Measurement (cd)	
	Min	Max	1 Minute	30 Minutes	1 Minute	30 Minutes
8U - 10L	100	600	251.5	217.2	302.1	230.4
8U - 10R	100	600	263.4	227.5	316.3	241.3
6U - 20L	100	600	293.8	253.7	322.5	246.0
6U - V	150	600	319.1	275.5	384.9	293.6
6U - 20R	100	600	302.2	260.9	335.9	256.2
4U - 30L	40	300	195.4	168.8	208.7	159.2
4U - 10L	200	600	409.2	353.4	473.9	361.5
4U - 10R	200	600	427.4	369.1	508.8	388.1
4U - 30R	40	300	208.6	180.2	213.2	162.6
H - 30L	100	300	253.5	218.9	264.2	201.5
H - 20L	150	600	459.1	396.5	505.7	385.7
H - V	200	600	491.3	424.4	592.3	451.9
H - 20R	150	600	464.5	401.1	511.4	390.1
H - 30R	100	300	258.6	223.3	268.9	205.1
4D - 30L	40	300	217.3	187.7	223.8	170.7
4D - 10L	200	600	451.1	389.6	509.2	388.4
4D - 10R	200	600	436.6	377.0	519.2	396.0
4D - 30R	40	300	209.2	180.7	216.8	165.4
6D - 20L	100	600	334.6	288.9	345.1	263.2
6D - V	150	600	351.0	303.1	402.2	306.8
6D - 20R	100	600	326.3	281.8	341.5	260.5
8D - 10L	100	600	306.5	264.7	322.4	245.9
8D - 10R	100	600	296.5	256.1	315.8	240.9

Test Results	<input checked="" type="checkbox"/> Passed	<input type="checkbox"/> Failed
--------------	--	---------------------------------

Test Results of Colour Measurement

Light Emitted Color : Amber
 By Day / By Night : By Day / By Night
 Color Boundaries - Limit towards green : $y \leq x - 0.120$
 - Limit towards red : $y \geq 0.390$
 - Limit towards white : $y \geq 0.790 - 0.670 x$

Test Points	<i>By Day, Measurement (x,y)</i>		<i>By Night, Measurement (x,y)</i>	
	<i>Sample 1 (12V)</i>	<i>Sample 2 (24V)</i>	<i>Sample 1 (12V)</i>	<i>Sample 2 (24V)</i>
Point 1	(0.5996, 0.4003)	(0.5945, 0.4045)	(0.5972, 0.4021)	(0.5942, 0.4049)
Point 2	(0.5992, 0.4000)	(0.5968, 0.4022)	(0.5971, 0.4022)	(0.5948, 0.4044)
Point 3	(0.5997, 0.3998)	(0.5960, 0.4031)	(0.5980, 0.4014)	(0.5956, 0.4038)
Point 4	(0.5983, 0.4004)	(0.5968, 0.4022)	(0.5985, 0.4009)	(0.5960, 0.4036)
Point 5	(0.5995, 0.3997)	(0.5975, 0.4021)	(0.5975, 0.4018)	(0.5955, 0.4037)
Test Results	<input checked="" type="checkbox"/> Passed <input type="checkbox"/> Failed			

<u>Test Results of Temperature Measurement</u>				
Lamp Function	: Amber Special Warning Lamp			
Requirement	: ECE Reg. 65 Para 5.6			
Test Requirement	: The special warning lamp shall remain assured at temperatures between - 20 °C and + 50 °C. Under the condition, one minute after a voltage equal to 90 percent of the rated voltage has been applied, the frequency shall remain between 2 and 4 Hz.			
Flash frequency measurement within temperature test :				
Test Sample	Temperature (°C)	Requirement (Hz)	Measurement (Hz)	
			By Day	By Night
<i>Sample 2</i>	-20	2.0 ~ 4.0	2.02	2.02
	50		2.05	2.05
Test Results	<input checked="" type="checkbox"/> Passed		<input type="checkbox"/> Failed	

<u>Test Results of Rain Test</u>				
Lamp Function	: Amber Special Warning Lamp			
Requirement	: ECE Reg. 65 Annex 4			
Visible Inspection	: Upon completion of the drain one hour later, the accumulated volume of water does not exceed 2 cm ³ .			
Flash frequency measurement within rain test :				
Test Sample	Requirement (Hz)		Measurement (Hz)	
	Min	Max	By Day	By Night
<i>Sample 3</i>	2.0	4.0	2.07	2.05
Test Results	<input checked="" type="checkbox"/> Passed		<input type="checkbox"/> Failed	

(Null below)

ECE INFORMATION DOCUMENT REF: AXIXTECH MS26 XA2 /00

JULUEN ENTERPRISE CO., LTD.
8F-1, No. 502, Da An Rd. Shulin District,
Xinbei City, Taiwan



AUTOMOTIVE certification
Business Class Kantorenpark
Jan Olieslagerslaan 35
B-1800 Vilvoorde
E-mail: homologation@vincotte.be
2012.08.03

SPECIAL WARNING LAMP

AXIXTECH MS26 XA2

Application: original
Date: June 27, 2012

Total number of pages: 4

ECE INFORMATION DOCUMENT REF: AXIXTECH MS26 XA2 /00

Manufacturer name and address: JULUEN ENTERPRISE CO., LTD.
8F-1, No. 502, Da An Rd. Shulin District,
Xinbei City, Taiwan

Trade name or mark : AXIXTECH

Type of device : MS26 XA2



AUTOMOTIVE certification
 Business Class Kantorenpark
 Jan Olieslagerslaan 35
 B-1800 Vilvoorde
 E-mail: homologation@vincotte.be

2012.08.03

SPECIFICATIONS

Function-Application-class category lamp and colour

Trade name or mark		<i>AXIXTECH</i>
Function		<i>Special warning lamp</i>
ECE Regulation		65-00 Supplement 7
Levels of intensity (Class)		Class 2
Used intensity system	by day	Normal system
	by night	Pulse width modulation (PWM) system
Category		Directional / Rotating / Stationary / complete bar flashing
Number, category and kind of light source(s)		12 LEDs / 4 light sources
Voltage and wattage		12V 18W / 24V 18W
Lens	Outer	Clear
	Filter (Inner)	Clear
Colour of light emitted		Amber / Red / Blue

TECHNICAL DATA

Part		Material	Remark
Lens	Outer	PC (polycarbonate)	Sabic ⁽¹⁾
	Filter (Inner)	PC (polycarbonate)	Sabic ⁽¹⁾
Reflector		-	-
Housing		ALUMINUM	ADC12

⁽¹⁾The base material of lens: Type number is LEXAN LS2 from Sabic Innovative Plastics.

MARKING

Marking		Location
Trade name or mark	AXIXTECH	See drawing
Approval marks	0028	See drawing

DRAWING REF: -- AXIXTECH MS26 XA2 / 00 -- dated 2012.06.20

A

B

C

D

E

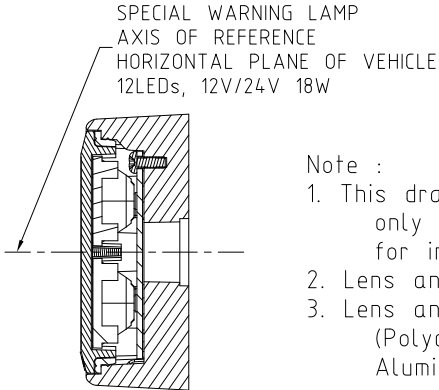
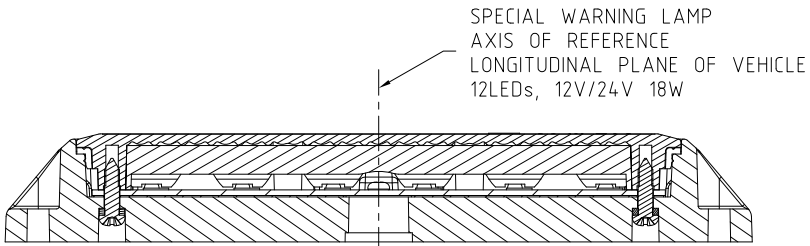
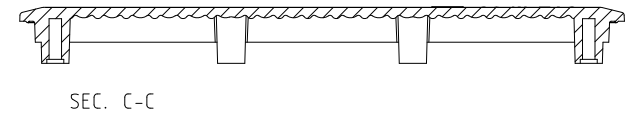
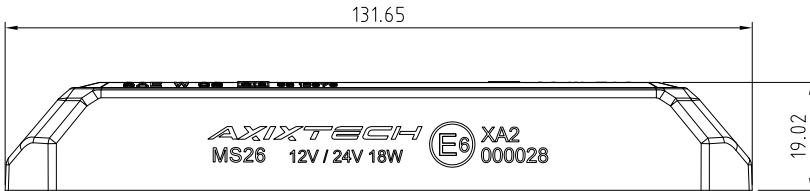
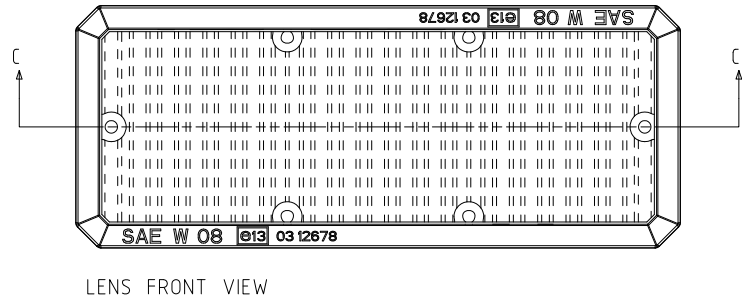
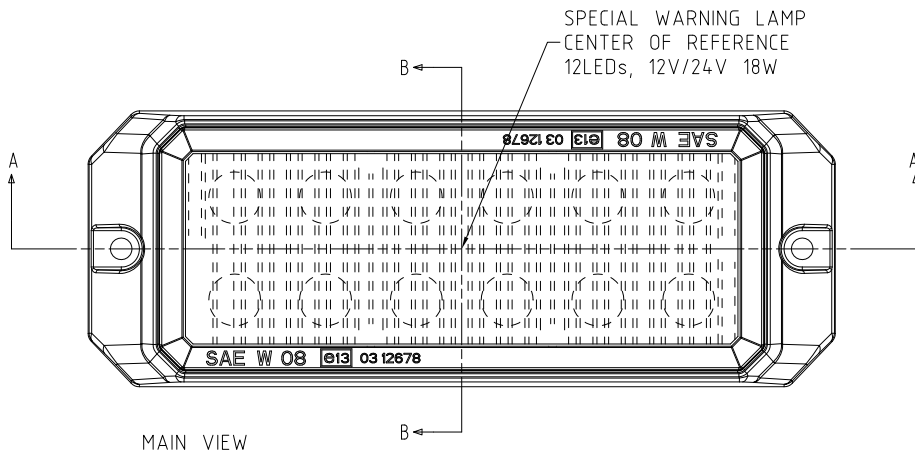

Note :

1. This drawing shall be applied of left hand only and the right hand is the same except for installed direction.
2. Lens and Base are secured with screws.
3. Lens and Collimator material (Polycarbonate), Base material (Die Cast Aluminum ADC12).



AUTOMOTIVE certification
Business Class Kantorenpark
Jan Olieslagerslaan 35
B-1800 Vilvoorde
E-mail: homologation@vincotte.be
2012.08.03



巨輪興業有限公司
JULUEN Enterprise Co.,Ltd.

MODEL	MS26S	TITLE	AXIXTECH (XA2)			
MATERIAL		PR.NO				
APPROVAL		DATE	PROJECTION			
CHECK		DATE	SCALE	1 : 1	UNITL	mm
DESIGNER	KEVIN	DATE	2012/07/10	SHEET	1 / 1	REV 1.0

Ⓟ 重點尺寸	ITEM	MODIFY	DATE
--------	------	--------	------

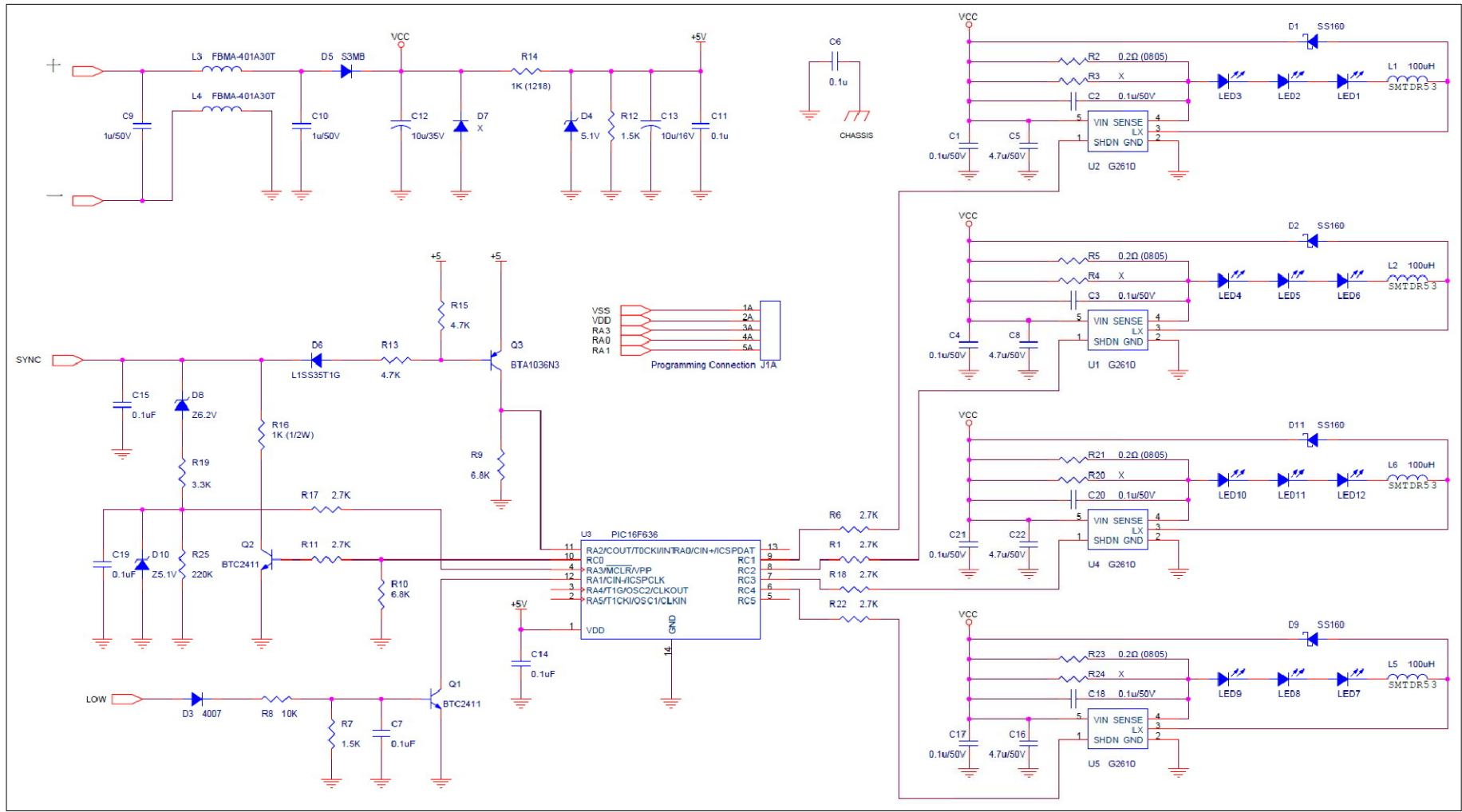

CIRCUIT DIAGRAM OF SPECIAL WARNING LAMP



AUTOMOTIVE certification
 Business Class Kantorenpark
 Jan Olieslagerslaan 35
 B-1800 Vilvoorde
 E-mail: homologation@vincotte.be
 2012.08.03



巨輪興業有限公司
 JULUEN Enterprise Co.,Ltd.

Ⓜ 重點尺寸

MODEL	MS26S	TITLE	AXIXTECH (XA2)		
MATERIAL		PR.NO			
APPROVAL		DATE	PROJECTION		
CHECK		DATE	SCALE	1 : 1	UNIT mm
DESIGNER	KEVIN	DATE	2012/07/10	SHEET	1 / 1
				REV	1.0